

1ST PRINTING FEB. 01

SEGA

NAOMI™

GD-ROM SYSTEM

SERVICE MANUAL

SEGA ENTERPRISES, INC. USA

MANUAL NO. 420 - 6620 -01

Warranty

Your new Sega Product is covered for a period of 90 days from the date of shipment. This certifies that the Printed Circuit Boards, Power Supplies and Monitor are to be free of defects in workmanship or materials under normal operating conditions. This also certifies that all Interactive Control Assemblies are to be free from defects in workmanship and materials under normal operating conditions. No other product in this machine is hereby covered.

Sellers sole liability in the event a warranted part described above fails shall be, at its option, to replace or repair the defective part during the warranty period. For Warranty claims, contact your Sega Distributor.

Should the Seller determine, by inspection that the product was caused by Accident, Misuse, Neglect, Alteration, Improper Repair, Installation or Testing, the warranty offered will be null and void.

Under no circumstances is the Seller responsible for any loss of profits, loss of use, or other damages.

This shall be the exclusive written Warranty of the original purchaser expressed in lieu of all other warranties expressed or implied. Under no circumstance shall it extend beyond the period of time listed above.

BEFORE USING THE PRODUCT, BE SURE TO READ THE FOLLOWING:

To maintain the safety:

To ensure the safe usage of the product, be sure to read the following before using the product. The following instructions are intended for the users, operators and the personnel in charge of the operation of the product. After carefully reading and sufficiently understanding the warning displays and cautions, handle the product appropriately. Be sure to keep this manual nearby the product or elsewhere convenient for referring to it when necessary.

Herein, explanations which require special attention are enclosed with dual lines. Depending on the potentially hazardous degrees, the terms of WARNING, CAUTION, etc. are used. Be sure to understand the contents of the displays before reading the text.



WARNING!

Indicates that mishandling the product by disregarding this warning will cause a potentially hazardous situation which can result in death or serious injury.



CAUTION!

Indicates that mishandling the product by disregarding this caution will cause a slight hazardous situation which can result in personal injury and or material damage.

For the safe usage of the product, the following pictographs are used:



Indicates "HANDLE WITH CARE." In order to protect the human body and equipment, this display is attached to places where the Owner's Manual and or Service Manual should be referred to.

○ Perform work in accordance with the instructions herein stated.

Instructions for work are explained by paying attention to the aspect of accident prevention. Failing to perform work as per the instructions can cause accidents. In the case where only those who have technical expertise should perform the work to avoid hazardous situation, the instructions herein state that the serviceman should perform such work.

○ Be sure to turn off power before working on the machine.

To prevent electric shock, be sure to turn off power before starting the work in which the worker touches the interior of the product. If the work is to be performed in the power-on status, the Instruction Manual herein always states to that effect.

○ Specification changes (removal of equipment, conversion and addition) not designated by SEGA are not allowed.

The parts of the product include warning labels for safety, covers for personal protection, etc. It is very hazardous to operate the product by removing parts and or modifying the circuits. Should doors, lids and protective parts be damaged or lost, refrain from operating the product, and contact where the product was purchased from or the office herein stated. SEGA shall not be held responsible for any accidents, compensation for damage to a third party, resulting from the specifications not designated by SEGA.

○ Be sure to adjust the monitor (projector) properly. (Applies only to the product w/monitor.)

Do not operate the product leaving on-screen flickering or blurring as it is. Using the product with the monitor not properly adjusted may cause dizziness or a headache to an operator, a player, or the customers.

○ When transporting or reselling this product, be sure to attach this manual to the product.

- Descriptions herein contained may be subject to improvement changes without notice.
- The contents described herein are fully prepared with due care. However, should any question arise or errors be found, please contact SEGA.

TABLE OF CONTENTS

BEFORE USING THE PRODUCT, BE SURE TO READ THE FOLLOWING:

TABLE OF CONTENTS

INTRODUCTION OF THE SERVICE MANUAL

1. HANDLING PRECAUTIONS	1
2. SPECIFICATIONS OF NAOMI GD-ROM SYSTEM	2 - 6
2 - 1 CABINET	2
2 - 2 NAOMI BD CASE AND FILTER BOARD	3
2 - 3 MONITOR DIRECTION AND HORIZONTAL SCANNING FREQUENCY	4
2 - 4 REPAIR / SERVICING AND CARTON BOX	5 - 6
3. ASSEMBLING THE NAOMI GD-ROM SYSTEM	7 - 20
3 - 1 CHECKING THE BOOT ROM VERSION NUMBER	9
3 - 2 BOOT ROM REPLACEMENT	10 - 11
3 - 3 DETACHING / ATTACHING THE DIMM BOARD CASE	12
3 - 4 KEY CHIP	13
3 - 5 GD-ROM DISK	14 - 15
3 - 6 CONNECTING THE POWER	16
3 - 7 REPLACING THE DIMM BOARD BATTERY PACK	17 - 19
3 - 8 BATTERY REPLACEMENT (NAOMI MAIN BD)	20
4. ERROR MESSAGE	20 - 24
5. SYSTEM TEST MODE	25 - 37
5 - 1 RAM TEST	26
5 - 2 JVS TEST	27
5 - 3 SOUND TEST	28
5 - 4 C.R.T. TEST	28
5 - 5 SYSTEM ASSIGNMENTS	29
5 - 6 COIN ASSIGNMENTS	30 - 34
5 - 7 BOOKKEEPING	35
5 - 8 BACKUP DATA CLEAR	36
5 - 9 CLOCK SETTING	36
5 - 10 DIMM BOARD TEST	37
5 - 11 GAME TEST MODE	37

INTRODUCTION OF THE OWNERS MANUAL

This Owner's Manual is intended to provide detailed descriptions together with all the necessary information covering the general operation of electronic assemblies, electromechanicals, servicing control, spare parts, etc. as regards the product, **NAOMI GD-ROM SYSTEM.**

This manual is intended for the owners, personnel and managers in charge of operation of the product. Operate the product after carefully reading and sufficiently understanding the instructions. If the product fails to function satisfactorily, non-technical personnel should under no circumstances touch the internal system. Please contact where the product was purchased from.

Use of this product is unlikely to cause physical injuries or damages to property. However, where special attention is required this is indicated by a thick line, the word "IMPORTANT" and its sign in this manual.



Indicates that mishandling the product by disregarding this display can cause the product's intrinsic performance not to be obtained, resulting in malfunctioning.

IMPORTANT

SEGA ENTERPRISES, INC. (U.S.A.)/CUSTOMER SERVICE
45133 Industrial Drive, Fremont, California 94538, U.S.A.
Phone : (415) 701-6580
Fax : (415) 701-6594

DEFINITION OF LOCATION MAINTENANCE MAN AND SERVICEMAN



Non-technical personnel who do not have technical knowledge and expertise should refrain from performing such work that this manual requires the location's maintenance man or a serviceman to carry out, or work which is not explained in this manual. Failing to comply with this instruction can cause a severe accident such as electric shock.

Ensure that parts replacement, servicing & inspections, and troubleshooting are performed by the location's maintenance man or the serviceman. It is instructed herein that particularly hazardous work should be performed by the serviceman who has technical expertise and knowledge.

The location's maintenance man and serviceman are herein defined as follows:

"Location's Maintenance Man" :

Those who have experience in the maintenance of amusement equipment and vending machines, etc., and also participate in the servicing and control of the equipment through such routine work as equipment assembly and installation, servicing and inspections, replacement of units and consumables, etc. within the Amusement Facilities and or locations under the management of the Owner and Owner's Operators of the product.

Activities of Location's Maintenance Man :

Assembly & installation, servicing & inspections, and replacement of units & consumables as regards amusement equipment, vending machines, etc.

Serviceman :

Those who participate in the designing, manufacturing, inspections and maintenance service of the equipment at an amusement equipment manufacturer.

Those who have technical expertise equivalent to that of technical high school graduates as regards electricity, electronics and or mechanical engineering, and daily take part in the servicing & control and repair of amusement equipment.

Serviceman's Activities :

Assembly & installation and repair & adjustments of electrical, electronic and mechanical parts of amusement equipment and vending machines.

1. HANDLING PRECAUTIONS



- To prevent electric shock or IC Board malfunctioning, be sure to turn off the power for the cabinet when installing or removing the IC Board.
- Extraneous matter such as dust on the IC Board can cause the IC Board to generate heat and result in a fire due to short circuit, etc. Ensure the IC Board surfaces are always kept clean.
- Keep the IC board well cooled.
The NAOMI board case and GD-ROM drive are provided with ventilating fans. Do not block the air outlets of these fans. Also do not place anything closely to the NAOMI board case and GD-ROM drive. Failure to observe these instructions may cause an overheating and fire.



- Be sure to connect the IC Board and connectors completely . Insufficient insertion can damage IC Board, etc.
- For the IC Board circuit inspection, only the use of Logic Tester is permitted. The use of ordinary testers is not permitted as these can damage the IC Board.
- Do not subject the IC Board to static electricity when installing the IC Board in the cabinet or when connecting wire harness connectors to the IC Board.
- When soldering buttons, etc. to the wire harnesses, be sure to remove the wire harnesses from the IC Board so as not to subject the IC Board to heat.
- Using NAOMI without the Shield Case can cause electric wave trouble. Be sure to use NAOMI together with the accessory Shield Case.
- The monitor frequency corresponding to NAOMI is 15kHz or 31kHz. NAOMI can not be used for the cabinet incorporating a monitor or projector not corresponding to 15kHz or 31kHz.
- Use the NAOMI board with the JVS-compatible cabinet. Using it with the non-JVS-compatible cabinet may cause an overheating and fire.

- Concerning the display of JAMMA VIDEO STANDARD:
JAMMA VIDEO STANDARD adopted by NAOMI is referred to as JVS. As against this Standard, the conventional JAMMA STANDARD which employs 56P Edge Connectors adopted by ST-V, etc. is displayed as Old JAMMA STANDARD.

The specific Manual attached to each game sometimes displays JVS as JV STANDARD, New JAMMA STANDARD, or JAMMA 2 STANDARD AGAINST OLD JAMMA STANDARD as JAMMA STANDARD, JS, etc.

- The contents herein described are subject to change without notice.

2. SPECIFICATIONS OF NAOMI GD-ROM SYSTEM

2 - 1 CABINET

- Use the NAOMI GD-ROM system with the JVS-compatible cabinet.
- If you want to use the NAOMI GD-ROM system with the conventional JAMMA-compatible cabinet, prepare the modification parts (power supply, I/O board, audio amplifier, etc.) and thereby modify the cabinet into a JVS-compatible one.
- Contact a cabinet manufacturer or distributor to check whether or not:
 - the cabinet is JVS-compatible and
 - the cabinet can be modified into a JVS-compatible one and used with the GD-ROM system.
- Some games may require not only a JVS-compatible cabinet but also a dedicated control panel.

2 - 2 NAOMI BD CASE AND FILTER BOARD

- NAOMI Main BD is contained in the Shield Case.
Use NAOMI in the status with the Main BD as is contained in the Shield Case.
- When using NAOMI, ensure that the Ventilation Ports and Heat Exhaust Fan opening are not obstructed.

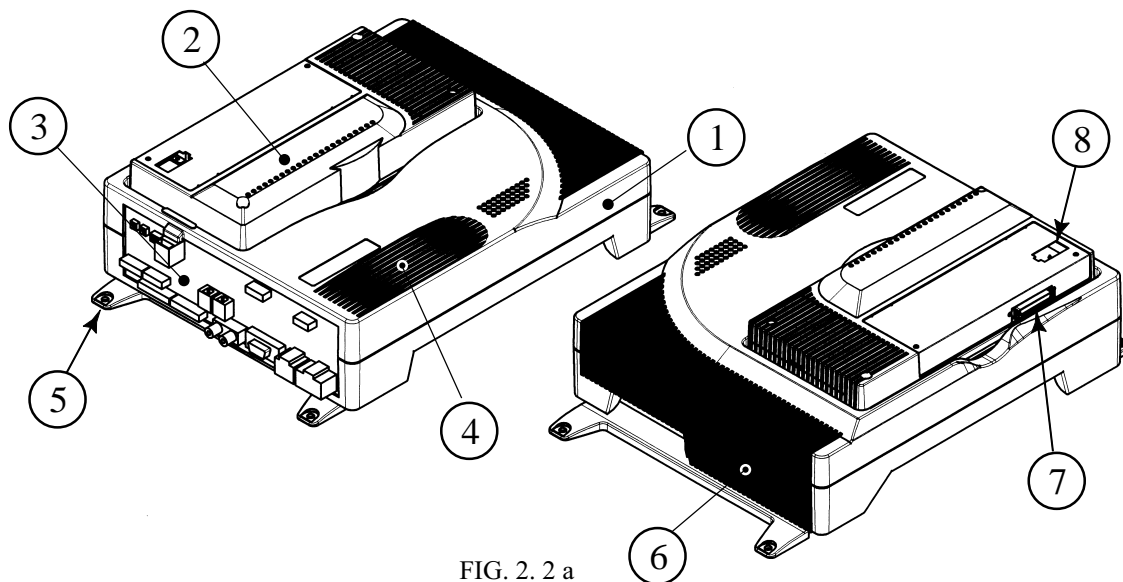

FIG. 2. 2 a

- | | | |
|---------------------|----------------------------|----------------------|
| ① NAOMI SHIELD CASE | ④ VENTILATION PORT | ⑦ GD Cable Connector |
| ② DIMM BOARD CASE | ⑤ LEG BRACKET | ⑧ Key Chip Slot |
| ③ FILTER BOARD | ⑥ HEAT EXHAUST FAN OPENING | |

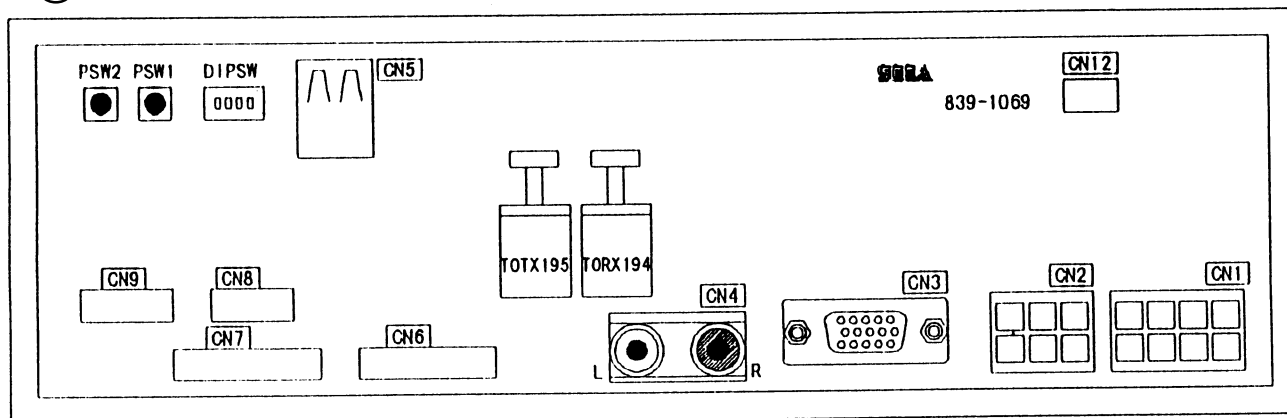

FIG. 2. 2 b

CN1: POWER SUPPLY (JST VL 8P) 1: (N.C.) 2: +3.3V 3: +5V 4: +12V 5~8: GND

CN2: POWER SUPPLY (JST VL 6P) 1: (N.C.) 2: +3.3V 3: +5V 4~6: GND

CN3: VIDEO OUTPUT (MINI D-SUB 15P)

CN4: STEREO-AUDIO OUTPUT(RCA PIN JACK FEMALE) RED: RIGHT WHITE: LEFT

CN5: STANDARD I/O (SERIES A TYPE) Connected to I/O BD via. USB Cable.

CN6 ~ 9,12: Normally not used.

TORX194,TOTX195: OPTIC FIBER CONNECTOR

Used for communication in-between plural NAOMI.

For application, refer to the Instruction Manual of the game for communication play.

PSW1: Functions as TEST Button.

PSW2: Functions as SERVICE Button.

DIPSW: Used for image Frequency change, etc.Refer to 2-3 MONITOR DIRECTION AND HORIZONTAL SCANNING FREQUENCY.

2 - 3 MONITOR DIRECTION AND HORIZONTAL SCANNING FREQUENCY

- MONITOR DIRECTION

Install the monitor in the positional direction (horizontal or vertical as applicable) suitable for each game. For the monitor direction, refer to the attached manual of the specific game. If the attached Instruction Manual dose not refer to the monitor direction, position the monitor in the horizontal direction.

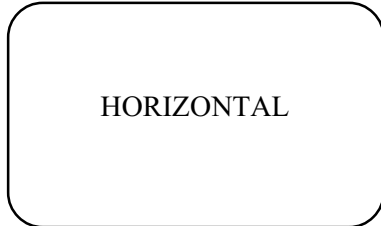

- HORIZONTAL SCANNING FREQUENCY : 15.85kHz / 31.69kHz

Which one of 15kHz or 31kHz frequency, or both of the frequencies does the game correspond to depends on each game. To find out the frequency the specific game corresponds to, refer to the Instruction Manual attached to the game.

The frequency output can be designated by No. 1 SW of DIP SW on the Filter BD.

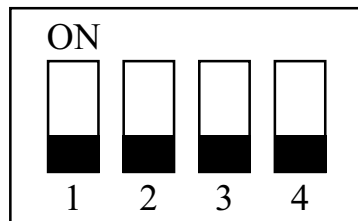

DIPSW 1 OFF
31kHz

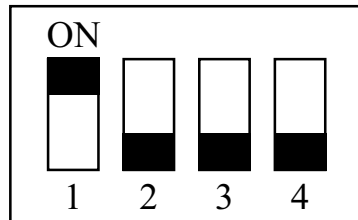

DIPSW 1 ON
15kHz

For both of 15K and 31K, set DIP SW 2&3 to OFF unless otherwise specified.

FIG. 2. 3 FILTER BOARD DIP SW

The actual DIP SW may differ from the above Figure.

Note that due to a certain flickering and blurring, the Interlace display may be slightly inferior as compared to Non-interlace display.

Also, if the cabinet monitor is not corresponding to Interlace display, on-screen noise may appear and display is not satisfactory.

Among the games corresponding to both 15k and 31k, there are some game for which the use of 31k is strongly recommended. If such a game is displayed in 15k, WARNING may be displayed at the time power is turned on.

At the time of the shipment of NAOMI Main BD, which one of 15k or 31k the DIP SW is set to depends on the games contained in the same package. Before installing in the cabinet, be sure to check the setting contents of DIP SW, and change the DIP SW setting if necessary.

2 - 4 REPAIR/SERVICING AND CARTON BOX

When transporting the NAOMI board and the GD-ROM drive for repair/servicing, follow the instructions below. The carton box (a standard accessory) is needed when transporting these components for repair/servicing. Carefully keep, therefore, the carton box.

- For repair/servicing, ship a set of the following parts:

① NAOMI board case

② DIMM board case

- * Do not remove the key chip but leave it attached.

③ GD-ROM drive

- * Remove the GD drive bracket.

- * Remove the GD-ROM disk and carefully keep it in its case.

- Remove all the wire harnesses and cables from the NAOMI board case and the GD-ROM drive before shipping them.
- Do not disassemble the NAOMI board case and the GD-ROM drive. Store them, just as they are, in the carton box.
- Make a report to explain the detailed symptoms as well as the name of the game you played. Send it to a repairer as instructed.

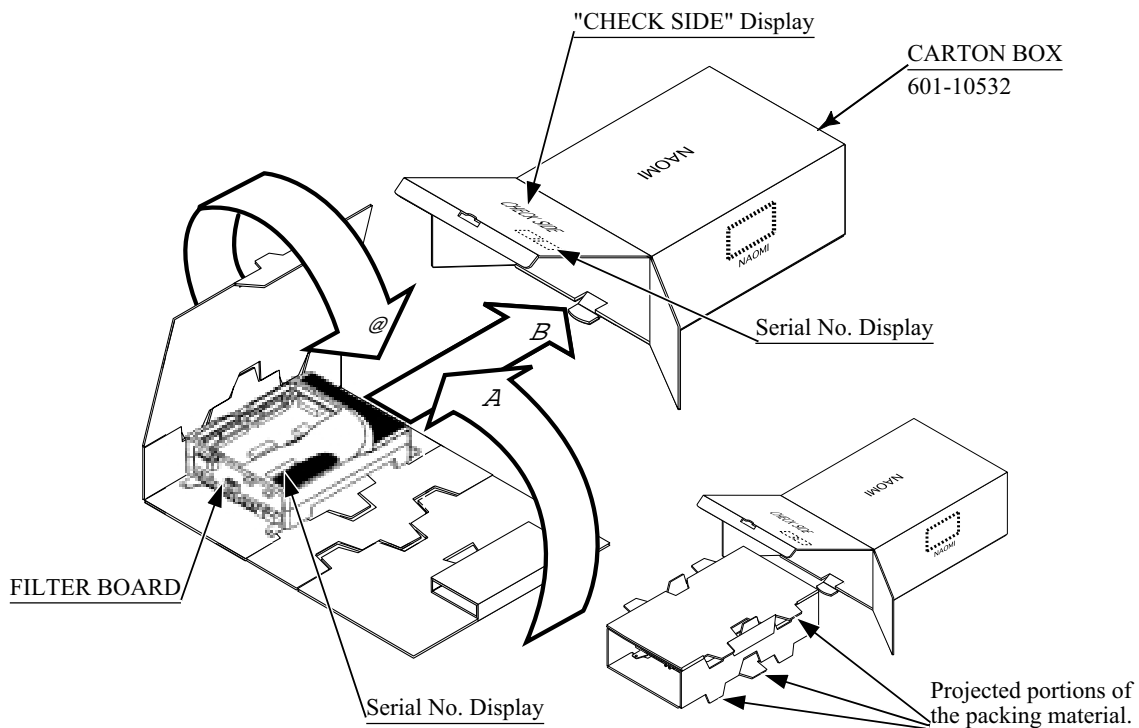

FIG. 2. 4 a

CARTON BOX
601-11030

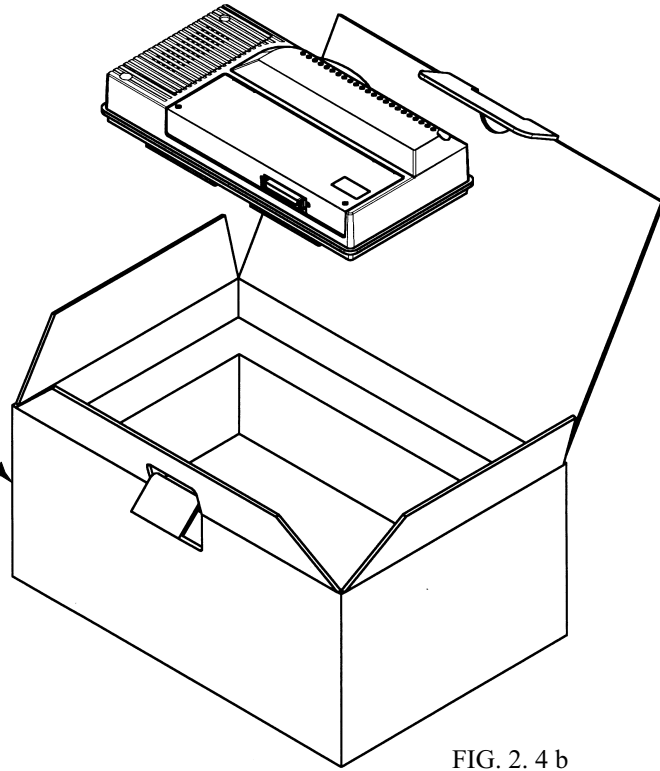
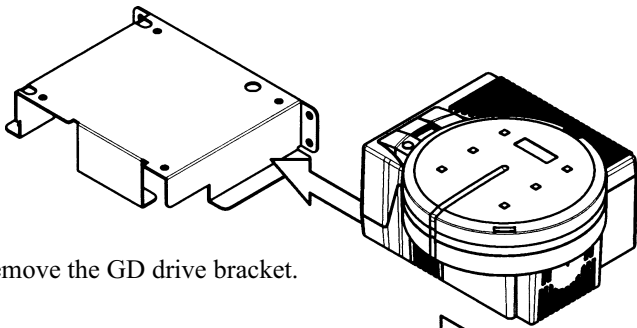

FIG. 2. 4 b

Remove the GD drive bracket.



CARTON BOX
601-11031

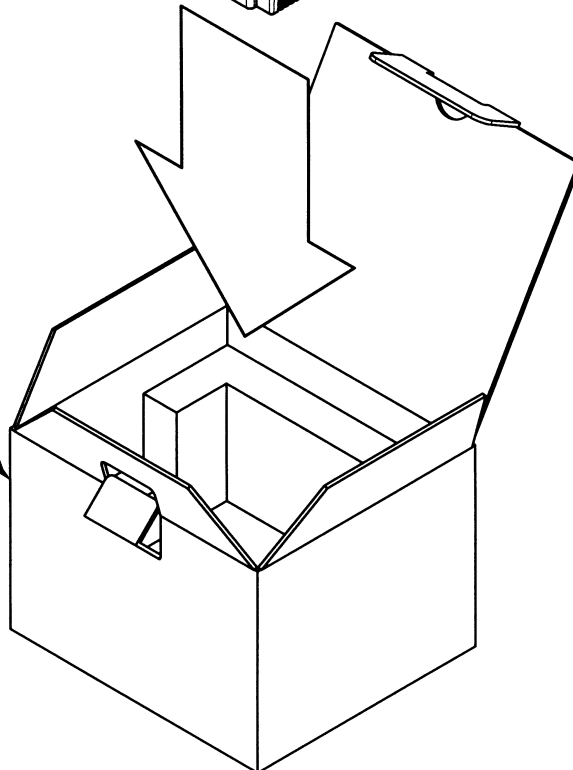

FIG. 2. 4 c

3. ASSEMBLING THE NAOMI GD-ROM SYSTEM



Before starting to work, ensure that the Power SW is OFF. Failure to observe this can cause electric shock and short circuit hazards.

Assemble the NAOMI GD-ROM system as follows:

When the GD-ROM system is used with:

- ① a standard cabinet that contains the NAOMI board:
- ② a JVS-compatible standard cabinet:

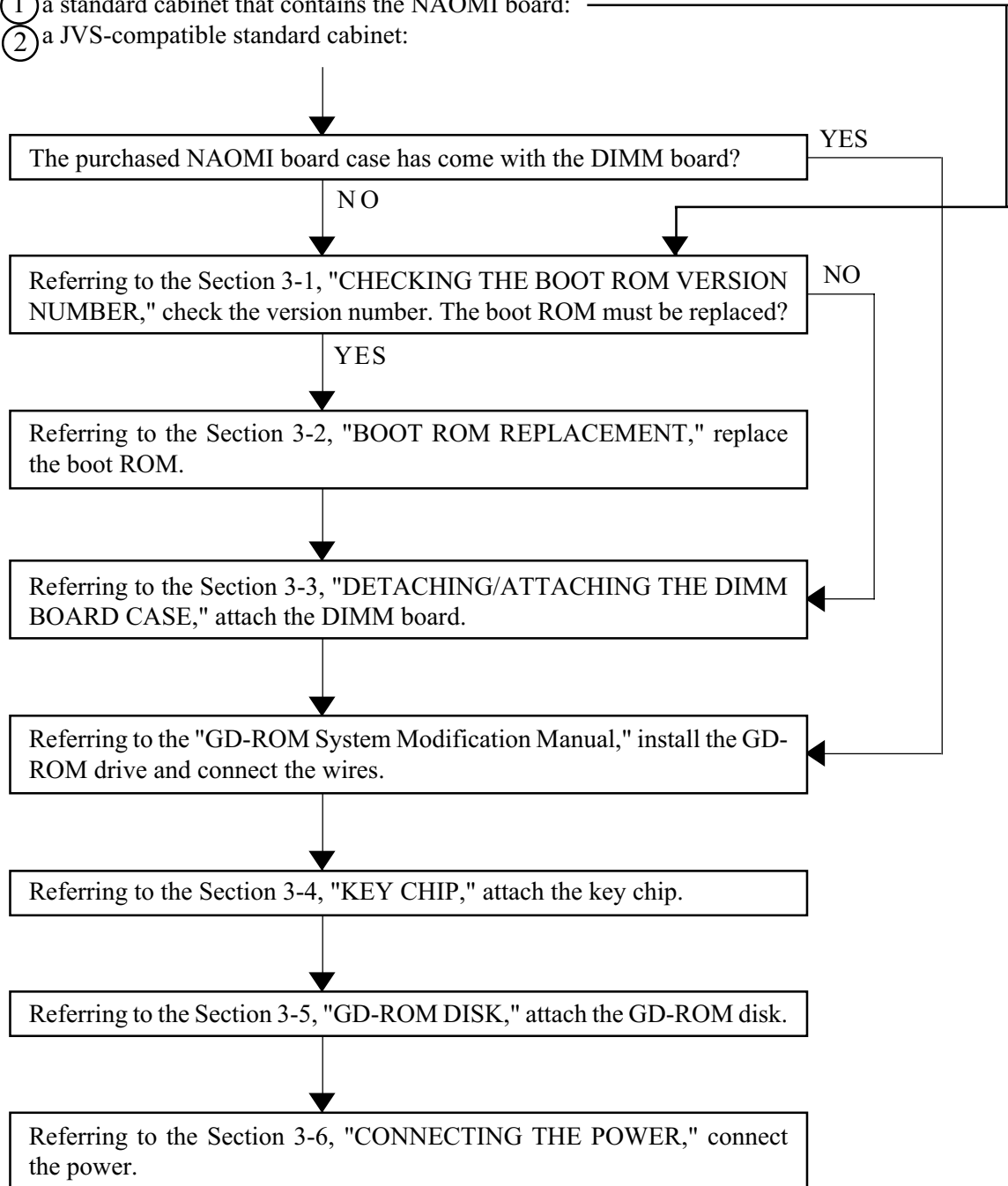

③ When the GD-ROM system is used with a dedicated game cabinet:

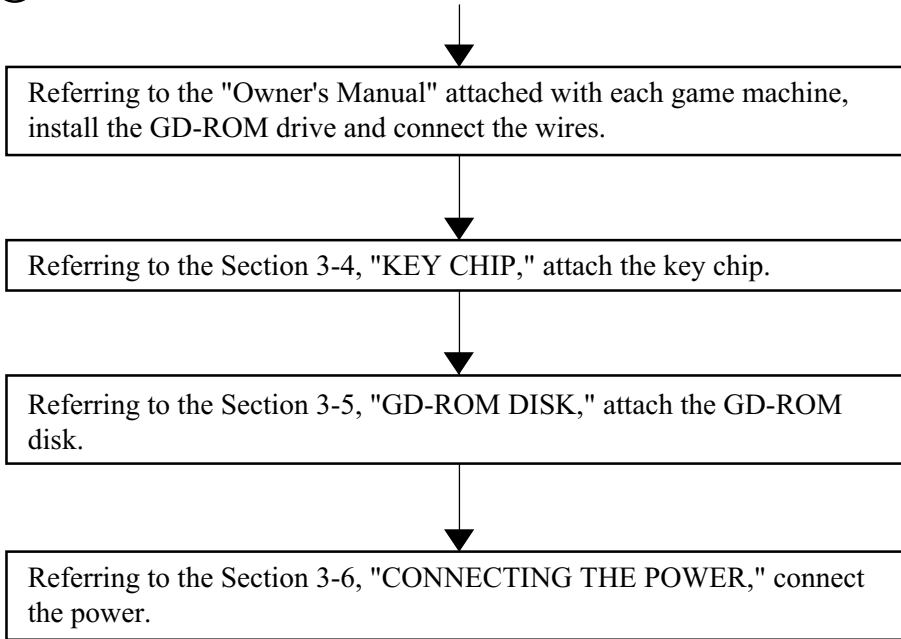

3 - 1 CHECKING THE BOOT ROM VERSION NUMBER

You can use the NAOMI main board for a GD-ROM system only if its boot ROM version number is EPR-xxxxE or later. The five-digit version number is indicated on the sticker of the boot ROM (IC27) of the NAOMI main board.

Visually check the boot ROM sticker and make sure that the version number is as follows:

EXAMPLE :	EPR-XXXXXD	X	(Not usable for a GD-ROM system)
	EPR-XXXXXE	○	(Usable for a GD-ROM system)
	EPR-XXXXXF	○	(Usable for a GD-ROM system)

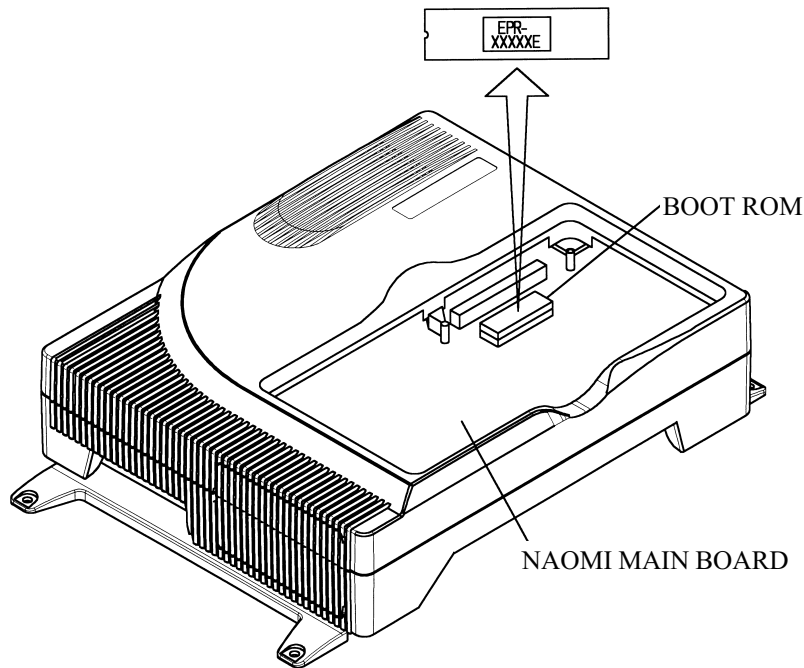

FIG. 3. 1

When the present boot ROM's version number is not EPR-xxxxD or before, replace the ROM with a new one of EPR-xxxxE or later.

When the present boot ROM's version number is EPR-xxxxE or later, but not latest, replace the ROM with a new one of the latest one.

Remember that the conventional ROM board is not usable even if it is attached with a GD-ROM system compatible boot ROM of EPR-xxxxE or later.

3 - 2 BOOT ROM REPLACEMENT



The ROM is a precision device. Handle it carefully because it may be damaged by heat, shock, and static electricity.

Do not perform this work unless otherwise particularly instructed due to BOOT ROM version change, etc.

- ① Remove on-socket ROM (IC27) of NAOMI Main BD from the socket by using an IC EXTRACTOR.
 - To prevent tearing off on-board patterns, etc., do not use tools such as a flat-blade type screwdriver, etc. other than the IC EXTRACTOR. For malfunctioning resulting from using tools other than the IC EXTRACTOR, repair shall be performed on a pay-basis. Be careful of this point.

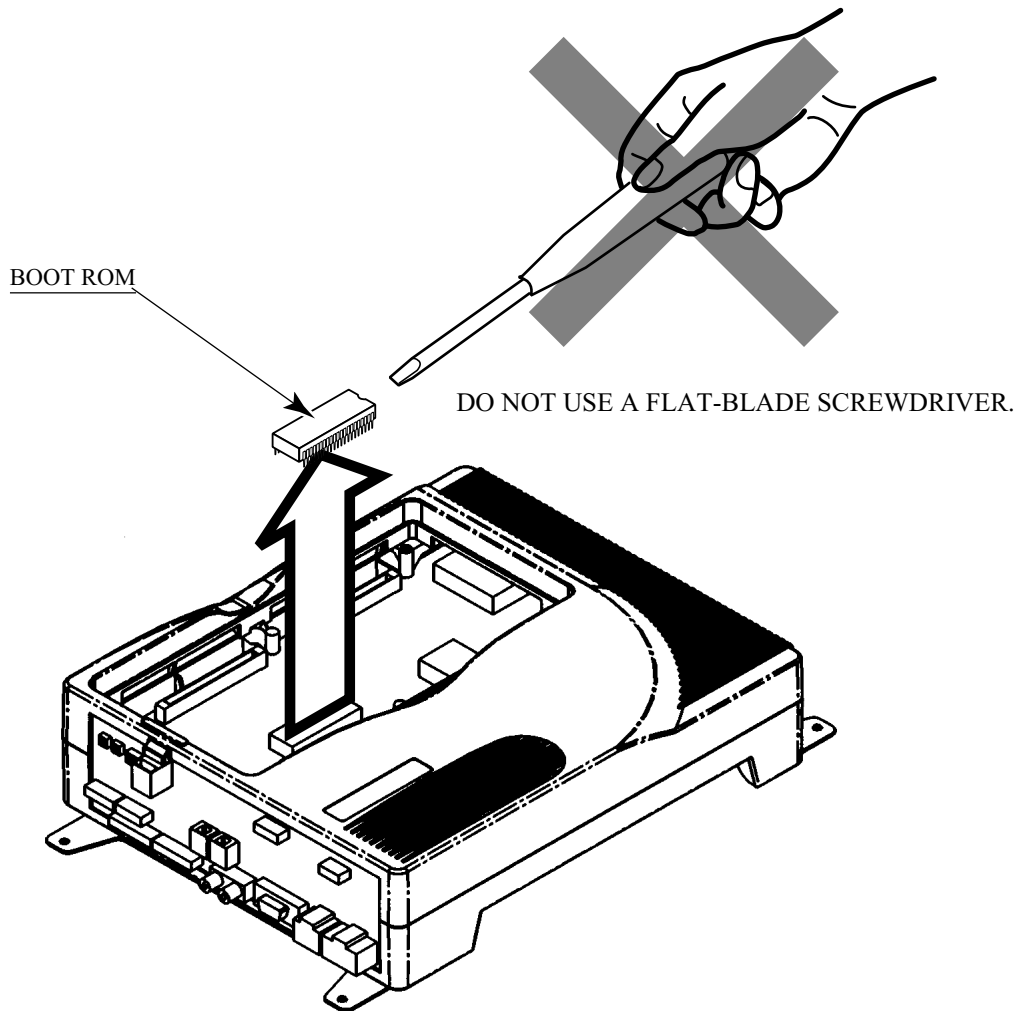

FIG. 3. 2 a

② Insert a new ROM into a socket; be careful about an inserting direction in this instance.

- It may be uneasy to insert a ROM, because the width between the two lines of pins on both ends may be larger than required. If this is the case, press the ROM pins onto a flat surface and bend them; thus make the width smaller.
- When inserting the ROM, be very careful to insert it into a correct direction and not to break its pins.

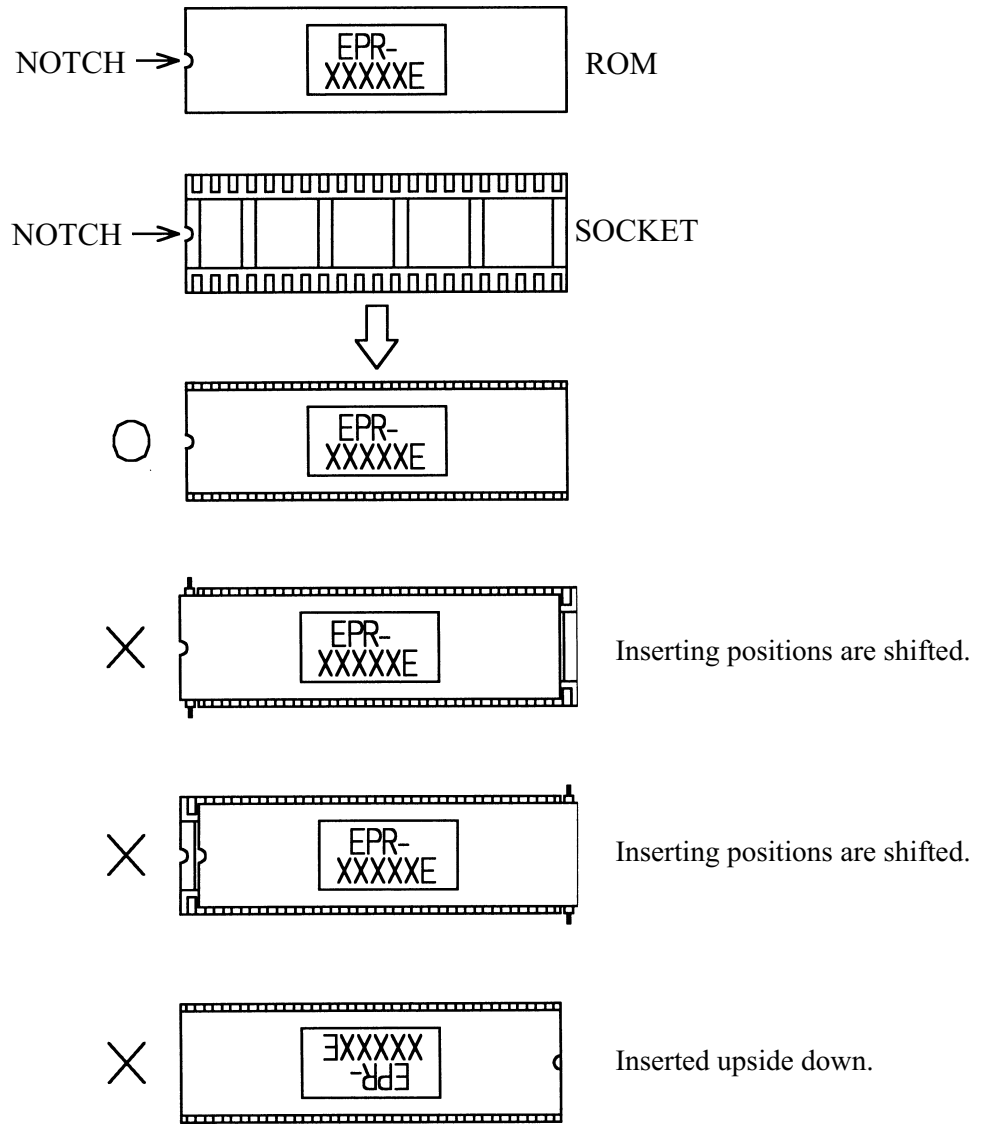

FIG. 3. 2 b

These wrongly inserted ROMs may be damaged when connecting the power.

3 - 3 DETACHING/ATTACHING THE DIMM BOARD CASE

How to Attach

- ① Contact the connectors with each other, and insert the DIMM board case into the NAOMI board case; be careful about an inserting direction in this instance. Make sure that the DIMM board case is seated firmly and completely.
- ② Use the three M3 X 30 screws and one M3 X 70 screw that fix the DIMM board case onto the NAOMI board case.

How to Detach

- ① Remove the three M3 X 30 screws and one M3 X 70 screw that fix the DIMM board case onto the NAOMI board case.
- ② Hold the ends of the DIMM board case and remove it upwards from the NAOMI board case.

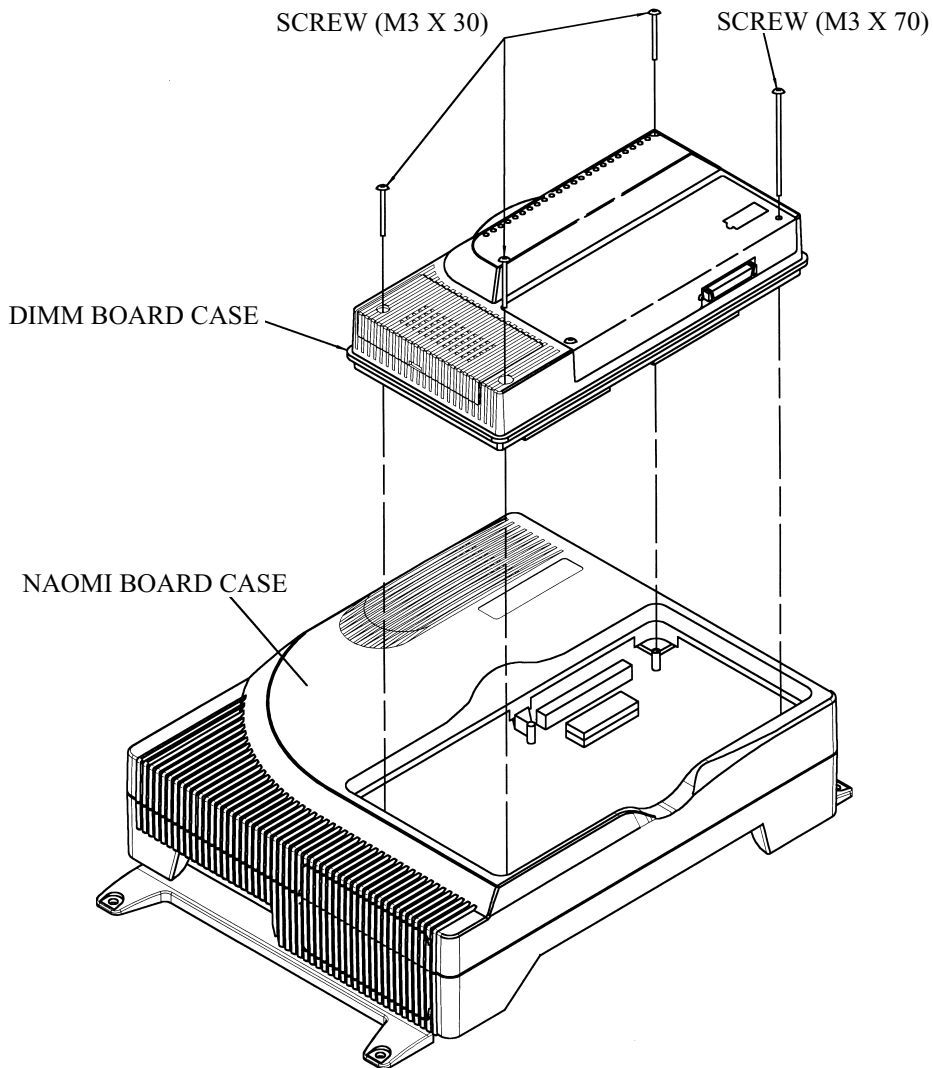

FIG. 3. 3

3 - 4 KEY CHIP



- The key chip is a precision device. Handle it carefully because it may be damaged by heat, shock, and static electricity.
- The key chip is contained in the GD-ROM disk case. Always use them as a set.

How to Attach

- ① Remove the key chip from the GD-ROM disk case.
- ② Insert the key chip vertically into the slot of the DIMM board case; be careful about an inserting direction in this instance. Make sure that the key chip is seated firmly and completely.

How to Detach

- ① Pressing the tab of the key chip, hold its end and remove it from the DIMM board case.
- ② Keep the GD-ROM disk and the key chip as a set.

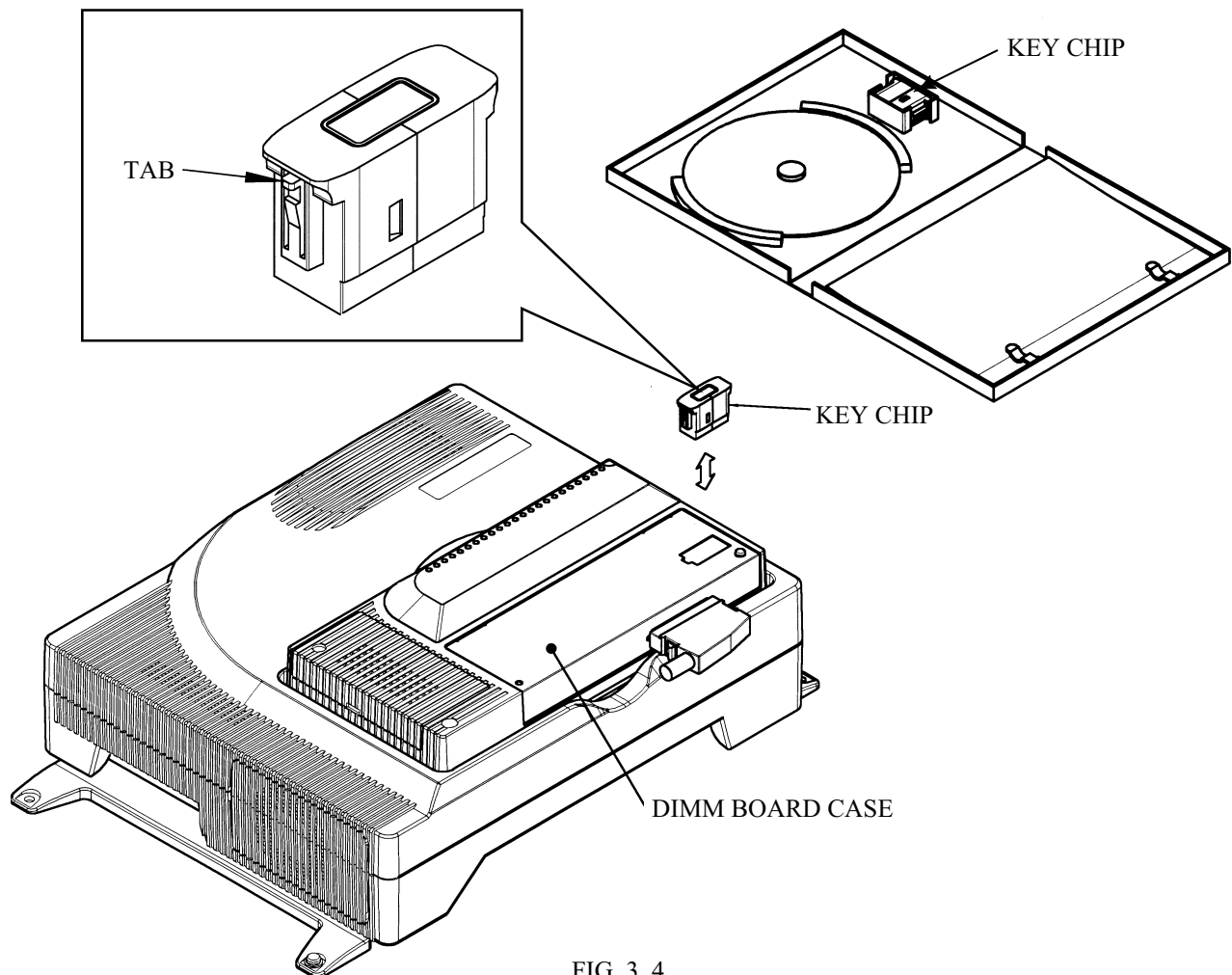

FIG. 3. 4



Handling the GD-ROM Disk

- Do not contaminate the disks with your fingerprints or dust particles. Contaminated disks may lower audio and video quality.
- When cleaning the disks, do not use volatile chemicals (benzine, thinner, etc.), cleaning sprays, and antistatic agents.
- Do not use cracked, warped, or damaged disks.
Do not attach papers or seals onto the disks; do not scratch the disks.
Do not use the disks with a sign of peeled seals, tapes, etc.
Observing these instructions, do not insert such a non-usable disk into the GD-ROM drive. Otherwise the inserted disk can not be ejected.
- When cleaning a heavily contaminated disk, use clean cloth that has been soaked in water and squeezed. Then remove moisture with dry cloth.
- When holding a disk, be careful not to contaminate it with your fingerprints.

Use clean cloth to wipe the disk gently into a radial direction.

How to Hold a Disk

With both hands:
Put your thumbs and forefingers of both hands on the disk's 4 edges.



With one hand:
Insert your forefinger into a central hole and at the same time put your thumb and middle finger on the disk's 2 edges.

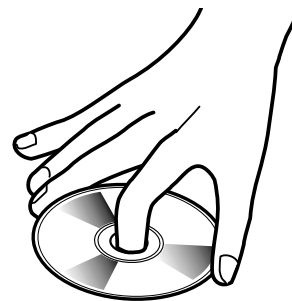

How to Attach

- ① Remove the 1 truss head screw that fixes the GD-ROM drive lid (DISC LID). And turn clockwise the lid to remove.
- ② Take out the GD-ROM disc from its case, and set it onto the GD-ROM drive with a labeled side facing you.
- ③ Return the lid to its original place, and fix it with 1 truss head screw. Be careful not to fasten it too tightly.

How to Detach

- ① Remove the 1 truss head screw that fixes the GD-ROM drive lid (DISC LID). And turn clockwise the lid to remove.
- ② Take out the GD-ROM disc and store it in the case. In this instance, be careful not to touch its grooves where the data is stored.
- ③ Return the lid to its original place, and fix it with 1 truss head screw. Be careful not to fasten it too tightly.

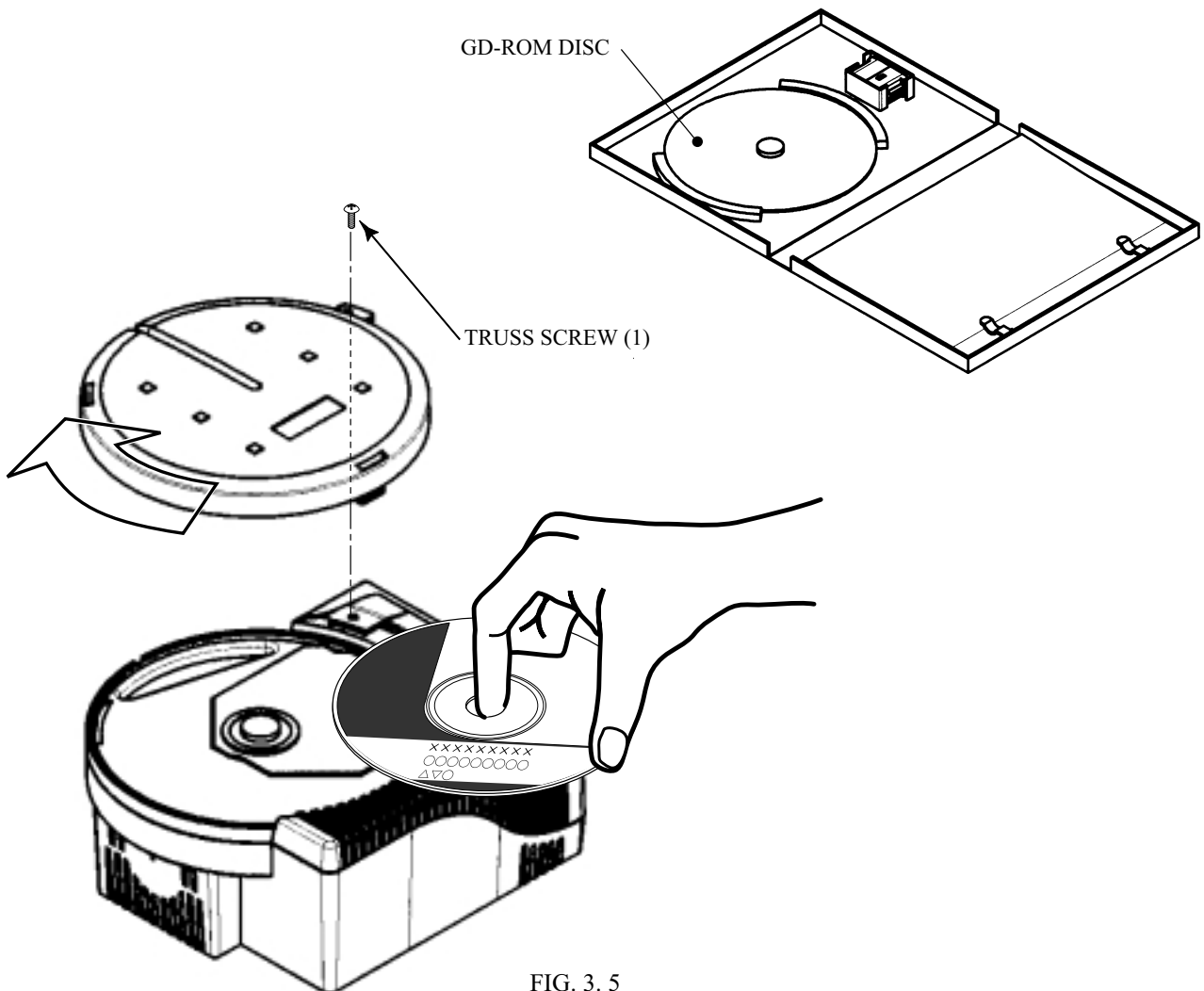

FIG. 3.5

3 - 6 CONNECTING THE POWER



CAUTION!

The disc in the GD-ROM drive starts to turn when the power is connected. If you open the GD-ROM drive lid in this instance, the disk may jump out causing danger. Disconnect the power in advance, therefore, when opening the lid. Do not open the lid immediately after disconnecting power, because the disk has inertia and can continue turning.



IMPORTANT

- Readout time varies depending on the charge of the DIMM board battery pack. It may be as long as several minutes when the power is connected for the first time or reconnected after a long-term power disconnection.
- Readout time varies depending on the game you play.

- ① After making sure that the system has been correctly assembled, connect the power to the cabinet.
 - ② Make sure that a NAOMI GD-ROM SYSTEM logo appears.
 - ③ Make sure that the system starts to read out the game from the GD-ROM. Percentage is displayed during readout.
 - ④ Make sure that a NAOMI GD-ROM SYSTEM logo reappears several minutes after readout.
 - ⑤ Make sure that an advertising screen appears.
- If an error message appears, immediately disconnect the power to the cabinet. Referring to the Section 4, "ERROR MESSAGE," take necessary actions and reconnect the power.
 - When a readout time seems to be longer than before, the cause may be a reduction of DIMM board battery pack's charge.
The DIMM board battery pack reduces its maximum charge each time when it is discharged/recharged. After discharging/recharging of about 500 times, the maximum charge may be only 70 to 80% of the initial charge. In other words, the DIMM board battery pack reaches its service life about 16 months after starting to use, based on that you connect and disconnect the power everyday. If this is the case, therefore, refer to the Section 3-7, "REPLACING THE DIMM BOARD BATTERY PACK" to replace the DIMM board battery pack.

3 - 7 REPLACING THE DIMM BOARD BATTERY PACK

Prohibitions and Cautions to Handle the Battery Pack

When handling the battery pack, observe the following instructions. If you do not observe the instructions described by this book, the Sega bears no responsibilities against any resulted problems.



- Do not disassemble.
Do not disassemble the battery pack and the batteries. If you should fail to observe this instruction, the internal wires and/or protective devices may be damaged; as a result the safety system may not function when discharging and recharging, eventually causing an overheating, fire and explosion. If you should disassemble the batteries, the generated gases may harm your throat and the negative plate may overheat and make a fire.
- Do not make a short circuit.
Do not make an external short circuit of the battery pack and the batteries. If you should fail to observe this instruction, the batteries may overheat, make a fire, and explode.
- Do not fire or heat.
Do not fire the battery pack and the batteries. If you should fail to observe this instruction, the batteries may make a fire and explode.
Do not leave the battery pack and the batteries nearby the heat source (fire or heater) or under the intense direct sunlight and flaming sun. If you should fail to observe this instruction, the batteries may reduce the service life and in the worst case may overheat, make a fire, and explode.
- Do not apply water or seawater.
Do not leave the battery pack and the batteries in water or seawater. Also do not apply water or seawater onto the battery pack and the batteries. If you should fail to observe this instruction, the internal wires and/or protective devices may be damaged; as a result the safety system may not function when discharging and recharging, eventually causing an overheating, fire and explosion. Also water may be electrolyzed into oxygen and hydrogen, and eventually the battery's sealed section may be corroded and the internal liquid may leak.
- Do not solder or heat.
Do not solder on the battery pack's terminals. If you should fail to observe this instruction, the armor may be heated and melted or the internal wires may be damaged, eventually causing an overheating, fire and explosion. Also, when the battery's temperature reaches to 100 Celsius or more, the battery may leak its internal liquid due to destruction of its plastic parts (gasket, separator, etc.), or may overheat, make a fire, or explode due to internal short-circuit.
- Do not insert or connect in a reversal polarity.
Do not insert or connect the battery in a reversal polarity. If you should fail to observe this instruction, the battery may be externally short-circuited and eventually overheat, make a fire, or explode, depending on the device you connect with.



- Do not tightly seal.
Do not tightly seal the battery pack when installing it onto an external device. Flammable gas is generated from the battery when its safety mechanism has functioned. If you should fail to observe the above-described instruction, sparks from motors, switches, etc. may cause the gas to fire. Therefore, install the battery pack so that the gas can be quickly released from the external device.
- Do not use for other applications.
Do not use the battery pack for the device/usage other than this game system. If you should fail to observe this instruction, the battery and/or the device may be damaged due to non-applicable specifications.
- Do not deform or shock.
Do not strike a nail in, hammer, step on, or apply any other forms of pressures and shocks on, the battery. If you should fail to observe this instruction, the battery may be deformed. As a result, the battery may burst at its sealed sections to leak the internal liquid, or may be short-circuited internally to overheat, make a fire, and explode.
- Do not recharge.
Do not use a battery charger because any battery charger is not usable for this battery pack. If you should fail to observe this instruction, the gas may be suddenly generated in the battery and eventually the battery may overheat, make a fire or explode.
- If the battery in use or in keeping shows an abnormal indication (deformation, change of color, bursting of the armor cover, etc.), immediately stop using or keeping it. If it leaks and smells abnormally, immediately keep it away from fire and put it in a safety box.
- If the liquid leaks from the battery and gets in your eyes, do not rub your eyes but immediately wash them with clean water (city water etc.); and consult a medical doctor for a treatment. If you should fail to observe this instruction, the liquid may harm your eyes.
- The battery pack armor (a polyvinyl chloride tube) may be damaged or deformed by external force or heat. When transporting the battery pack or replacing it with a new one, therefore, be careful not to drop or excessively shock it. Do not continue to use any damaged or deformed battery pack. If you should fail to observe this instruction, the battery may overheat, make a fore, or explode.
- The battery pack contains a printed circuit board (PCB) for protective circuitry. It may be destroyed by the static electricity. When handling or servicing the battery pack, therefore, take preventive measures against the static electricity.
If your battery pack has shown destruction of a protective circuitry PCB, do not continue to use it. If you should fail to observe this instruction, the battery may overheat, make a fore, or explode.
- When wiring the battery pack to a device, be careful not to apply excessive force onto the connectors and lead wires. The battery may overheat, make a fire, or explode if the connectors and lead wires are damaged.
- Do not do away with the used battery packs carelessly because they may contaminate the environment. Submit them to an industrial waste disposal plant.
- Pack the used battery packs and thereby avoid damaging them, before delivering them to an industrial waste disposal plant.

When a GD-ROM readout time seems to be longer than before, the cause may be a reduction of DIMM board battery pack's charge. Usually, the DIMM board battery pack reaches its service life about 16 months after starting to use.

Do not use a battery charger because any battery charger is not usable for this battery pack. Instead, replace the battery pack with a new one as follows:

- ① Using a Phillips-head screwdriver, lift up the battery cover and thus remove it from the DIMM board case.
- ② Press the tab of the battery pack connector and pull it; thus remove it from the DIMM board.
- ③ Firmly connect the connector of a new battery pack into the DIMM board.
- ④ Return the battery cover to the DIMM board case.

Submit the used battery packs to an industrial waste disposal plant. Thus they must be disposed according to the local laws and regulations.

DIMM Board Battery Pack

SEGA PART No. 401-0076

SEGA PART NAME BATTERY PACK CGR-B/241A

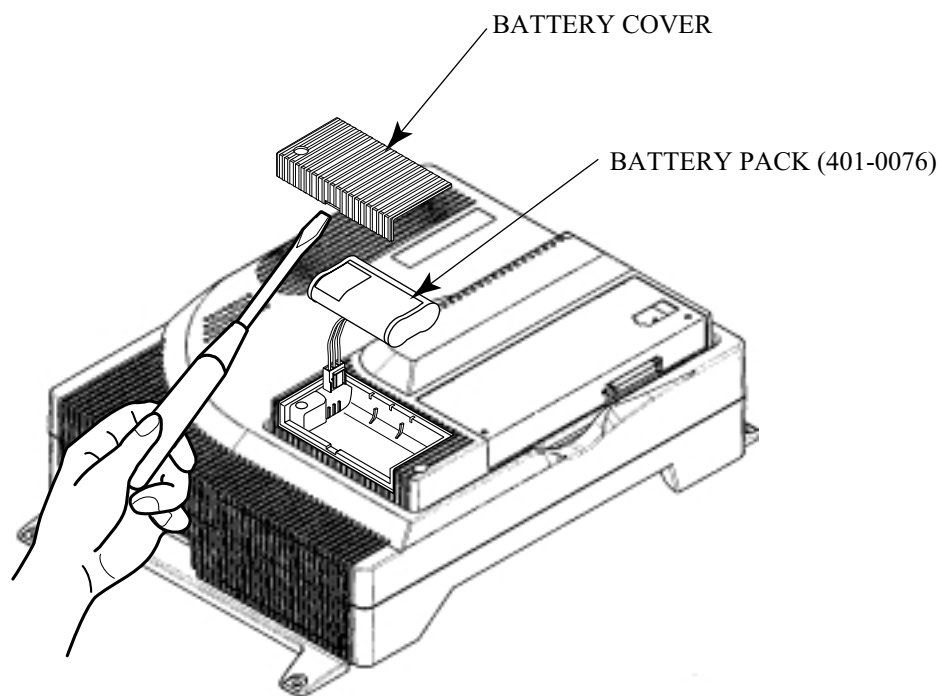

FIG. 3. 7

3 - 8 BATTERY REPLACEMENT (NAOMI MAIN BD)

Except for special cases such as using up the battery, etc., do not perform this work.

- ① Turn power off, and remove ROM BD Case from NAOMI Case by referring to 3-3 DETACHING/ATTACHING THE DIMM BOARD CASE above.
- ② Carefully remove the battery on the Battery Holder of NAOMI Main BD.
- ③ With the positive pole facing upward, insert the new Battery (CR2032) into the Holder.
- ④ By referring to 3-3 DETACHING/ATTACHING THE DIMM BOARD CASE, reinstall ROM BD Case to NAOMI Case.

Dispose the removed batteries according to the local laws and regulations.

NAOMI main Board Battery
SEGA PART No. 401-0054
SEGA PART NAME BATTERY CR2032/1F MATSUSHITA

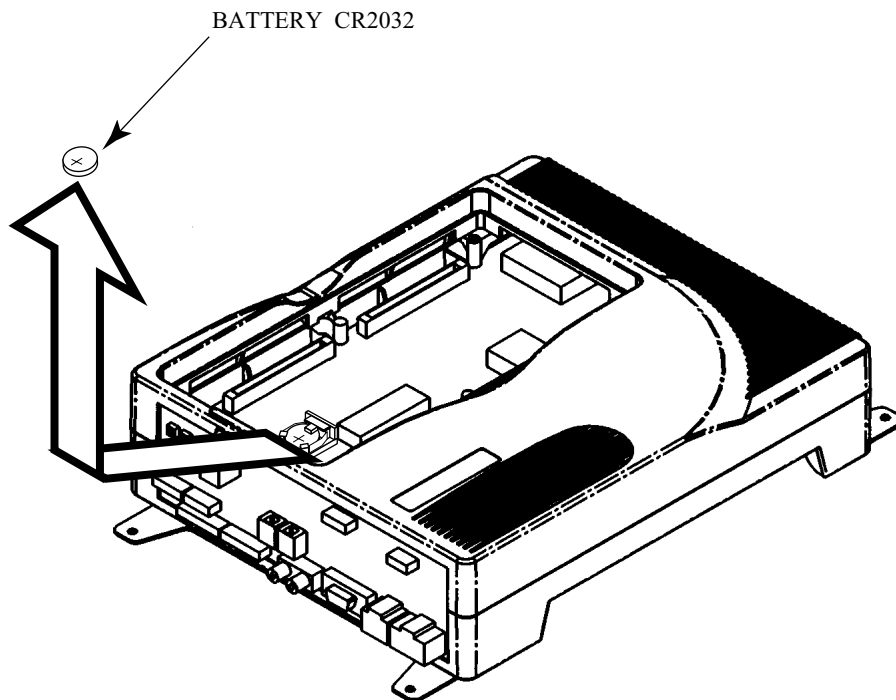

FIG. 3. 8

4. ERROR MESSAGE

In the following cases, ERROR MESSAGE is displayed at the time power is turned on and the test mode is finished, and the game is not playable.

ERROR 01

[DISPLAY] ERROR 01
THIS GAME IS NOT ACCEPTABLE
BY MAIN BOARD.

[CAUSE] The ROM BOARD (or DIMM BOARD) is not connected correctly to the MAIN BD correctly.

[COUNTERMEASURES] First, turn power off, connect the ROM BD (or DIMM BOARD) correctly. If the status is not improved yet, the board may be malfunctioning.

ERROR 02

[DISPLAY] ERROR 02
THIS GAME IS NOT ACCEPTABLE
BY MAIN BOARD.

[CAUSE] A game of a certain country's version which is not compatible with the Main BD is connected to the Main BD.

[COUNTERMEASURES] Connect a game of a country's version which is compatible with the Main BD. Country setting change can not be preformed in the TEST mode.

ERROR 03

[DISPLAY] ERROR 03
BOARD MALFUNCTIONING.

[CAUSE] Main board serial number cannot be read out.

[COUNTERMEASURES] Submit the DIMM board for repairing. (See Sections 2-4 and 3-3.)

ERROR 04

[DISPLAY] ERROR 04
BOARD MALFUNCTIONING.

[CAUSE] DIMM board serial number cannot be read out.

[COUNTERMEASURES] Submit the NAOMI board with the DIMM board for repairing. (See Section 2-4.)

ERROR 21
[DISPLAY] ERROR 21
THIS GAME IS NOT ACCEPTABLE BY MAIN BOARD.
[CAUSE] Game data (loaded from the GD-ROM to the DIMM board) are corrupted.
[COUNTERMEASURES] Make sure that the GD-ROM drive is firmly connected to the NAOMI board.
Make sure that the GD-ROM disk is not scratched or contaminated.

ERROR 22
[DISPLAY] ERROR 22
COMMUNICATION ERROR OCCURRED BETWEEN MAIN BOARD
AND OPTION BOARD.
[CAUSE] The NAOMI main board receives no responses from the DIMM board.
[COUNTERMEASURES] Correctly reconnect the DIMM board and the GD interface board. If the
problem is still reproduced, replace the DIMM board and/or the GD
interface board.

ERROR 23
[DISPLAY] ERROR 23
GD-ROM DRIVE COVER IS OPEN.
[CAUSE] The GD-ROM drive cover is open.
[COUNTERMEASURES] Close the cover firmly.

ERROR 24
[DISPLAY] ERROR 24
GD-ROM IS NOT FOUND.
[CAUSE] The NAOMI GD-ROM disk can not be recognized.
[COUNTERMEASURES] Reinsert the NAOMI GD-ROM disk.
Make sure that the GD-ROM disk is not scratched or contaminated.

ERROR 25
[DISPLAY] ERROR 25
CAN NOT ACCESS GD-ROM DRIVE.
[CAUSE] (1) The GD-ROM drive can not be accessed. (2) The GD-ROM drive cover
is open.
[COUNTERMEASURES] (1) Correctly reconnect the GD cable and power cord to the GD-ROM drive.
If the problem is still reproduced, replace the GD-ROM drive. (2) Close the
cover firmly.

ERROR 26
[DISPLAY] ERROR 26
OPTION BOARD MALFUNCTIONING.
[CAUSE] The NAOMI board key chip can not be recognized.
[COUNTERMEASURES] Make sure that you are using a correct key chip that meets the GD-ROM
disk (If not so, change the present key chip with a correct one). Also make
sure that the key chip is firmly inserted.

ERROR 27

[DISPLAY] ERROR 27
DIMM MEMORY IS NOT ENOUGH.

[CAUSE] (1) The capacity of the DIMM memory on the DIMM board is not sufficient.
(2) The DIMM memory is not firmly connected.

[COUNTERMEASURES] (1) Add the memory as required by the software you are using. (2) Firmly reconnect the DIMM memory on the DIMM board.

CAUTION 51

[DISPLAY]

CAUTION 51
GAME ASSIGNMENTS ARE
INCORRECT.
SET CORRECTLY IN SYSTEM
ASSIGNMENTS OF TEST MODE.

[CAUSE]

CABINET TYPE setting is not correct for the game.

[COUNTERMEASURES]

Enter the TEST mode and change the CABINET TYPE setting of SYSTEM ASSIGNMENTS to the setting suitable for the game.

For the correct setting, refer to the Instruction Manual attached to the game. Certain games require the replacement of Control Panel.

CAUTION 52

[DISPLAY]

CAUTION 52
CHANGE VIDEO OUTPUT OF
THIS GAME TO THE SETTING
CORRESPONDING TO HORIZONTAL
SCANNING FREQUENCY 15kHz.

[CAUSE]

31kHz is employed when the game is corresponding to Horizontal Scanning Frequency of 15kHz only.

[COUNTERMEASURES]

Set the monitor to 15kHz, and No. 1 of NAOMI FILTER BD DIP SW to ON.

For the setting method of monitor's Frequency, refer to the Instruction Manual of the cabinet. If the monitor is not corresponding to 15kHz, the game is not playable.

CAUTION 53

[DISPLAY]

CAUTION 53
CHANGE VIDEO OUTPUT OF
THIS GAME TO THE SETTING
CORRESPONDING TO HORIZONTAL
SCANNING FREQUENCY 31kHz.

[CAUSE]

15kHz is employed when the game is corresponding to Horizontal Scanning Frequency of 31kHz only.

[COUNTERMEASURES]

Set the monitor to 31kHz, and No. 1 of NAOMI FILTER BD DIP SW to ON.

For the setting method of monitor's Frequency, refer to the Instruction Manual of the cabinet. If the monitor is not corresponding to 31kHz, the game is not playable.

CAUTION 54

[DISPLAY]

CAUTION 54
GAME ASSIGNMENTS ARE
INCORRECT.
SET CORRECTLY IN SYSTEM
ASSIGNMENTS OF TEST MODE.

[CAUSE]

The setting of MONITOR TYPE differs from the correct setting of the game.

[COUNTERMEASURES]

Enter the TEST mode, and change the MONITOR TYPE setting of MONITOR TYPE in SYSTEM ASSIGNMENTS to the correct setting suitable for the game. For the correct setting, refer to the Instruction Manual attached to the game. If necessary, perform Horizontal/Vertical transposition of the monitor, as applicable.

5. SYSTEM TEST MODE



- The contents of setting changes in SYSTEM ASSIGNMENTS, COIN ASSIGNMENTS, and GAME TEST MODE are stored when the test mode is EXITed. If the power is turned off before EXITing, the contents of setting changes are ineffective. Be very careful of this point.
- Do not activate a system test mode while the system is reading out and checking the GD-ROM. If you do so, you can not activate a game test mode, or an error message may appear on the screen when you exit a system test mode.

This test mode mainly allows the IC Board to be checked for accurate functioning, monitor color to be adjusted as well as COIN ASSIGNMENTS and GAME ASSIGNMENTS to be adjusted.

- ① After turning power on, press the TEST button to have the following test item menu displayed.

```
SYSTEM MENU
JAPAN VERSION

RAM TEST
JVS TEST
SOUND TEST
C.R.T. TEST
SYSTEM ASSIGNMENTS
COIN ASSIGNMENTS
BOOKKEEPING
BACKUP DATA CLEAR
CLOCK SETTING

DIMM BOARD TEST-----
GAME TEST MODE
[*****]-----

-> EXIT

SELECT WITH SERVICE BUTTON
AND
PRESS TEST BUTTON
```

This item is indicated as ROM BOARD TEST if a ROM board is connected.
Game name is entered.

- ② Press the SERVICE button to move the arrow. Bring the arrow to the desired item and press the TEST button.
- ③ Select the GAME TEST MODE item and press the test button. The system displays a test menu screen specific to each game.
For further information about a system test mode, see the Service Manual that comes with each game.
- ④ Upon finishing the test, bring the arrow to EXIT and press the TEST button to return to the Game mode.

5 - 1 RAM TEST

This screen enables to test the performance of the RAM on the NAOMI main board. Immediately when this screen appears, the system starts to test. The TESTING NOW message is displayed on the screen while the system is testing.

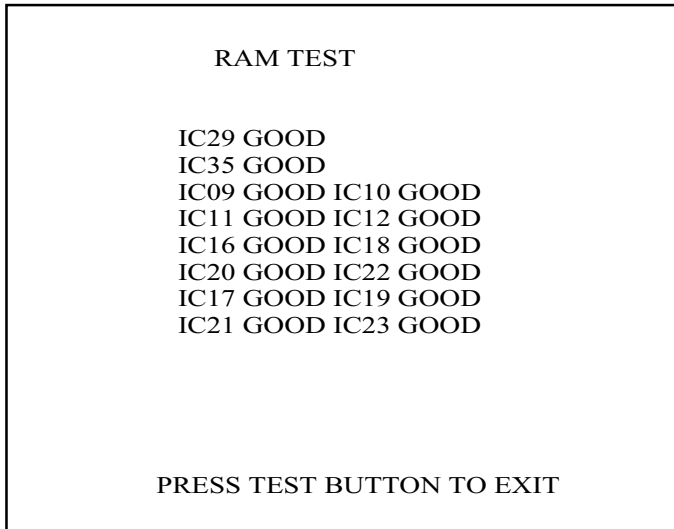

The GOOD message appears on the right of a RAM if it has been judged as normal while BAD if abnormal. It takes about 2 minutes and 20 seconds to complete testing all the RAMs. After testing, press the TEST button to return to the system menu screen.

5 - 2 JVS TEST

In this test, Specifications of the I/O Board connected to NAOMI can be checked, and INPUT TEST can be performed. First, I/O Board Specifications are displayed.

```

                JVS TEST
                INPUT TEST      (A)
                NEXT NODE      (B)
-              > EXIT         (C)
NODE          1/1
NAME         SEGA ENTERPRISES,LTD.
            I/O 838-18683
            VER 1.04
            98/12
CMD VER     1.1
JVS VER     2.0
COM VER     1.0
SWITCH      2PLAYER(S) 11BITS
COIN        2SLOT
ANALOG      8CH
ROTARY      0CH
KEYCODE     0
SCREEN      X:0 Y:0 CH:0
CARD        OSLOT
HOPPER OUT  0CH
DRIVER OUT  8SLOT
ANALOG OUT  0CH
CHARACTER   CHARA:0 LINE:0
BACKUP      0

SELECT WITH SERVICE BUTTON
AND
PRESS TEST BUTTON
    
```

1 2 3
Name and version of I/O BOARD.

Select with the SERVICE button and press the TEST button.

- (A) INPUT TEST : Proceeds to the INPUT TEST of I/O BOARD being displayed.
- (B) NEXT NODE : In the case where more than 2 I/O Boards are connected, proceeds to the next I/O Board.
- (C) EXIT : Returns to the menu mode.

INPUT TEST SCREEN

```

                JVS TEST
                INPUT TEST
                NEXT NODE
                -> EXIT

NODE 1/1

SWITCH -----
SYSTEM  00000000
PLAYER1 00000000
        00000000
PLAYER2 00000000
        00000000

COIN -----
0000 0000
ANALOG -----
0000 0000 0000 0000
0000 0000 0000 0000

SELECT WITH SERVICE BUTTON
AND
PRESS TEST BUTTON
    
```

When INPUT is performed for the switches of Control Panel, etc., the value changes to 1 from 0.

If the Coin SW is inputted, the count starts. When the TEST MODE is finished, the count is cleared and returned to 0000.

Analogue values are displayed between 0000 and FF00.

5 - 3 SOUND TEST

Sound Output test can be performed. Beep sounds can be emitted from each of left/right Speakers.

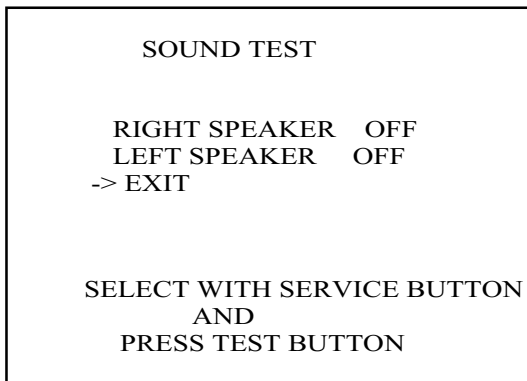

- Emitted from the right-hand side Speaker.
- Emitted from the left-hand side Speaker.
- Returns to the menu mode.

5 - 4 C.R.T. TEST

A) RGB COLOR ADJUSTMENT SCREEN

In this page, monitor color can be checked.

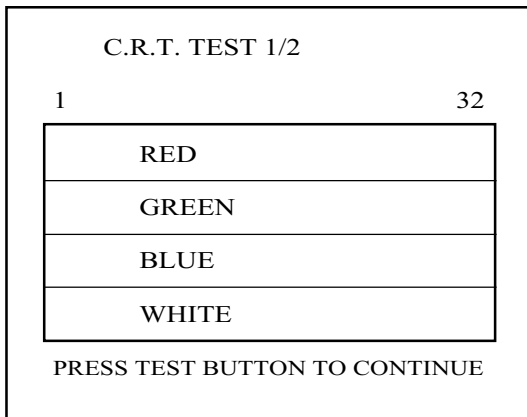

Each of red, green, and blue is the darkest at the leftmost end, and becomes brighter towards the right-hand end in 31 gradations. Monitor brightness is satisfactory if the white color bar is black at the left end and if it is white at the right end.

Press the TEST button to proceed to the next page.

B) MONITOR SIZE ADJUSTMENT SCREEN

In this page, monitor size can be checked.

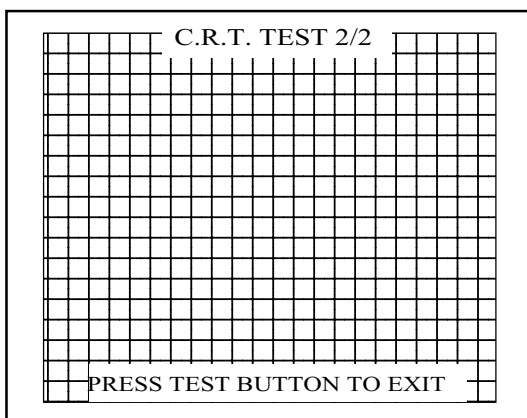

Adjust so that the checkered patterns do not go beyond the screen.

Press the TEST button to return to the menu mode.

5 - 5 SYSTEM ASSIGNMENTS



If the settings of CABINET TYPE and MONITOR TYPE are not suitable for the connected game, Error Message is displayed after turning power on and upon finishing the TEST mode, and in this case, game is not playable. For the contents of settings suitable for each game, refer to the Instruction Manual attached to the game. Especially, when there is no special notes or descriptions, perform the settings as seen fit by judging from the statuses of cabinet and control panel Specifications.

The settings of cabinet and board can be changed. Game related assignments such as game difficulty, etc. are performed in 5-11 GAME TEST MODE.

- ① Press the SERVICE button to move the arrow. Bring the arrow to the desired item.
- ② Press the TEST button to change the setting.
- ③ Upon finishing the setting, move the arrow to EXIT and press the TEST button.

```
SYSTEM ASSIGNMENTS

CABINET TYPE  2PLAYER(S)  (A)
ADVERTISE SOUND ON      (B)
MONITOR TYPE  HORIZONTAL  (C)
SERVICE TYPE  COMMON     (D)
-> EXIT

SELECT WITH SERVICE BUTTON
AND
PRESS TEST BUTTON
```

(A) CABINET TYPE (1PLAYER(S), 2PLAYER(S), 3PLAYER(S), 4PLAYER(S))

Sets the number of players between 1 and 4.

(B) ADVERTISE SOUND (ON, OFF)

Sets whether ADVERTISE sound is to be emitted or not.

(C) MONITOR TYPE (HORIZONTAL, VERTICAL)

Sets the on-screen display to the positional direction of monitor (HORIZONTAL/VERTICAL)

HORIZONTAL: Normal on-screen display

VERTICAL: On-screen display when the monitor is vertically positioned as against normal HORIZONTAL position.

(D) SERVICE TYPE (COMMON, INDIVIDUAL)

Sets the functioning of when the SERVICE button is pressed, in case that several SERVICE buttons exist.

COMMON: By pressing any SERVICE button, Service credit can be obtained for all Players.

INDIVIDUAL: By pressing SERVICE button, Service credit can be obtained for the Player corresponding to the SERVICE button pressed.

5 - 6 COIN ASSIGNMENTS

In this mode, the setting of incremental credit increase as against coin insertion can be changed.

- ① Press the SERVICE button to move the arrow. Bring the arrow to the desired item.
- ② Press the TEST button to change the setting.
- ③ Upon finishing the setting, bring the arrow to EXIT and press the TEST button.

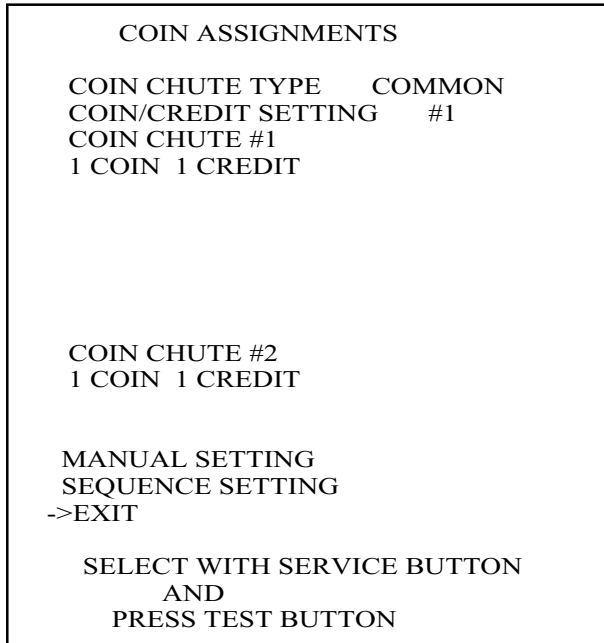

FIG. 5 - 6 A (Setting to COMMON)

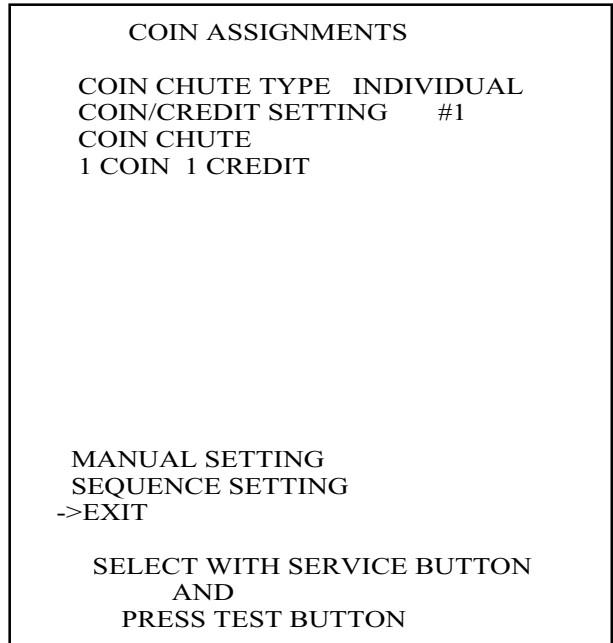

FIG. 5 - 6 B (Setting to INDIVIDUAL)

(A) COIN CHUTE TYPE (COMMON, INDIVIDUAL)

Perform setting in the manner corresponding to Coin Chute Specifications.

COMMON

This setting is for the cabinet which has a coin chute(s) for common use by plural players. Up to 2 Coin Chutes (#1 and #2) can be used and also, (B) COIN/CREDIT SETTING ratio can be set separately for #1 and #2.

INDIVIDUAL

This setting is for the cabinet in which each player uses an independent coin chute. Coins inserted by each player are handled as the player's credits. Depending on the CABINET TYPE setting in the SYSTEM ASSIGNMENTS and the functioning of the connected I/O Board, the number of Coin SW INPUT ports varies between 1 and 4. (B) COIN/CREDIT SETTING ratio is common for each Coin Chute.

(B) COIN/CREDIT SETTING (# 1 ~ # 27)

Sets the credit increase increment per coin insertion. There are 27 settings from #1 to #27, expressed in ○○ credit(s) as against ○○ coins inserted. #27 refers to FREE PLAY. For details, refer to Table 1 (COMMON) and Table 2 (INDIVIDUAL).

(C) MANUAL SETTING

The Credit's incremental increase settings as against a coin insertion are shown in further details than in (B) above (refer to Table 3). Also, note that when this MANUAL SETTING is performed, (B) COIN CREDIT setting becomes ineffective.

MANUAL SETTING

```
COIN ASSIGNMENTS
MANUAL SETTING

COIN TO CREDIT      1
BONUS ADDER        NO BONUS ADDER
COIN CHUTE #1 MULTIPLIER
1 COIN COUNT AS 1 COIN
COIN  1 2 3 4 5 6 7 8 9
CREDIT 1 2 3 4 5 6 7 8 9

COIN CHUTE #2 MULTIPLIER
1 COIN COUNT AS 1 COIN
COIN  1 2 3 4 5 6 7 8 9
CREDIT 1 2 3 4 5 6 7 8 9

SEQUENCE SETTING

->EXIT

SELECT WITH SERVICE BUTTON
AND
PRESS TEST BUTTON
```

FIG. 5 - 6 C (Setting to COMMON)

```
COIN ASSIGNMENTS
MANUAL SETTING

(D) COIN TO CREDIT      1
(E) BONUS ADDER        NO BONUS ADDER
COIN CHUTE MULTIPLIER
1 COIN COUNT AS 1 COIN
COIN  1 2 3 4 5 6 7 8 9
CREDIT 1 2 3 4 5 6 7 8 9

(G) SEQUENCE SETTING

->EXIT

SELECT WITH SERVICE BUTTON
AND
PRESS TEST BUTTON
```

FIG. 5 - 6 D (Setting to INDIVIDUAL)

(D) COIN TO CREDIT

Determines COIN/CREDIT setting.

(E) BONUS ADDER

This sets how many coins should be inserted to obtain one SERVICE COIN.

(F) COIN CHUTE (# 1 / # 2) MULTIPLIER

This sets how many tokens one coin represents.

Table 1: COIN/CREDIT SETTING (COIN CHUTE COMMON TYPE)

NAME OF SETTING	COIN CHUTE 1		COIN CHUTE 2	
SETTING #1	1 COIN	1 CREDIT	1 COIN	1 CREDIT
SETTING #2	1 COIN	2 CREDITS	1 COIN	1 CREDIT
SETTING #3	1 COIN	3 CREDITS	1 COIN	1 CREDIT
SETTING #4	1 COIN	4 CREDITS	1 COIN	1 CREDIT
SETTING #5	1 COIN	5 CREDITS	1 COIN	1 CREDIT
SETTING #6	1 COIN	2 CREDITS	1 COIN	2 CREDITS
SETTING #7	1 COIN	5 CREDITS	1 COIN	2 CREDITS
SETTING #8	1 COIN	3 CREDITS	1 COIN	3 CREDITS
SETTING #9	1 COIN	4 CREDITS	1 COIN	4 CREDITS
SETTING #10	1 COIN	5 CREDITS	1 COIN	5 CREDITS
SETTING #11	1 COIN	6 CREDITS	1 COIN	6 CREDITS
SETTING #12	2 COINS	1 CREDIT	2 COINS	1 CREDIT
SETTING #13	1 COIN	1 CREDIT	2 COINS	1 CREDIT
SETTING #14	1 COIN	2 CREDITS	2 COINS	1 CREDIT
SETTING #15	1 COIN	1 CREDIT	1 COIN	1 CREDIT
	2 COINS	3 CREDITS	2 COINS	3 CREDITS
SETTING #16	1 COIN	3 CREDITS	1 COIN	1 CREDIT
			2 COINS	3 CREDITS
SETTING #17	3 COINS	1 CREDIT	3 COINS	1 CREDIT
SETTING #18	4 COINS	1 CREDIT	4 COINS	1 CREDIT
SETTING #19	1 COIN	1 CREDIT	1 COIN	1 CREDIT
	2 COINS	2 CREDITS	2 COINS	2 CREDITS
	3 COINS	3 CREDITS	3 COINS	3 CREDITS
	4 COINS	5 CREDITS	4 COINS	5 CREDITS
SETTING #20	1 COIN	5 CREDITS	1 COIN	1 CREDIT
			2 COINS	2 CREDITS
			3 COINS	3 CREDITS
			4 COINS	5 CREDITS
SETTING #21	5 COINS	1 CREDIT	5 COINS	1 CREDIT
SETTING #22	1 COIN	2 CREDITS	3 COINS	1 CREDIT
			5 COINS	2 CREDITS
SETTING #23	2 COINS	1 CREDIT	2 COINS	1 CREDIT
	4 COINS	2 CREDITS	4 COINS	2 CREDITS
	5 COINS	3 CREDITS	5 COINS	3 CREDITS
SETTING #24	1 COIN	3 CREDITS	2 COINS	1 CREDIT
			4 COINS	2 CREDITS
			5 COINS	3 CREDITS
SETTING #25	1 COIN	1 CREDIT	1 COIN	1 CREDIT
	2 COINS	2 CREDITS	2 COINS	2 CREDITS
	3 COINS	3 CREDITS	3 COINS	3 CREDITS
	4 COINS	4 CREDITS	4 COINS	4 CREDITS
	5 COINS	6 CREDITS	5 COINS	6 CREDITS
SETTING #26	1 COIN	6 CREDITS	1 COIN	1 CREDIT
			2 COINS	2 CREDITS
			3 COINS	3 CREDITS
			4 COINS	4 CREDITS
			5 COINS	6 CREDITS
SETTING #27	FREE PLAY		FREE PLAY	

Table 2: COIN/CREDIT SETTING (COIN CHUTE INDIVIDUAL TYPE)

NAME OF SETTING	EACH SEAT'S COIN CHUTE	NAME OF SETTING	EACH SEAT'S COIN CHUTE
SETTING #1	1 COIN 1 CREDIT	SETTING #21	5 COINS 1 CREDIT
SETTING #2	1 COIN 2 CREDITS	SETTING #23	2 COINS 1 CREDIT
SETTING #3	1 COIN 3 CREDITS		4 COINS 2 CREDITS
SETTING #4	1 COIN 4 CREDITS		5 COINS 3 CREDITS
SETTING #5	1 COIN 5 CREDITS	SETTING #25	1 COIN 1 CREDIT
SETTING #11	1 COIN 6 CREDITS		2 COINS 2 CREDITS
SETTING #12	2 COINS 1 CREDIT		3 COINS 3 CREDITS
SETTING #15	1 COIN 1 CREDIT		4 COINS 4 CREDITS
	2 COINS 3 CREDITS		5 COINS 6 CREDITS
SETTING #17	3 COINS 1 CREDIT	SETTING #27	FREE PLAY
SETTING #18	4 COINS 1 CREDIT		
SETTING #19	1 COIN 1 CREDIT		
	2 COINS 2 CREDITS		
	3 COINS 3 CREDITS		
	4 COINS 5 CREDITS		

Table 3: MANUAL SETTING

COIN TO CREDIT	1	COIN	1 CREDIT
	2	COINS	1 CREDIT
	3	COINS	1 CREDIT
	4	COINS	1 CREDIT
	5	COINS	1 CREDIT
	6	COINS	1 CREDIT
	7	COINS	1 CREDIT
	8	COINS	1 CREDIT
	9	COINS	1 CREDIT

BONUS ADDER	NO BONUS ADDER		
	2	COINS GIVE	1 EXTRA COIN
	3	COINS GIVE	1 EXTRA COIN
	4	COINS GIVE	1 EXTRA COIN
	5	COINS GIVE	1 EXTRA COIN
	6	COINS GIVE	1 EXTRA COIN
	7	COINS GIVE	1 EXTRA COIN
	8	COINS GIVE	1 EXTRA COIN
	9	COINS GIVE	1 EXTRA COIN

COIN CHUTE (#1 / #2) MULTIPLIER	1	COIN COUNTS AS	1 COIN
	1	COIN COUNTS AS	2 COINS
	1	COIN COUNTS AS	3 COINS
	1	COIN COUNTS AS	4 COINS
	1	COIN COUNTS AS	5 COINS
	1	COIN COUNTS AS	6 COINS
	1	COIN COUNTS AS	7 COINS
	1	COIN COUNTS AS	8 COINS
	1	COIN COUNTS AS	9 COINS

(G) SEQUENCE SETTING

Number of credits required for starting game, etc. can be set.
 Function varies depending on the specific games. To find out what kind of functions are allotted to each sequence, or what is the initial value for each sequence, refer to the Instruction Manual of the game connected. Each sequence can be set between 1 to 5 credit(s).

COIN ASSIGNMENTS	
SEQUENCE SETTING	
SEQUENCE 1	1 CREDIT(S)
SEQUENCE 2	1 CREDIT(S)
SEQUENCE 3	1 CREDIT(S)
SEQUENCE 4	1 CREDIT(S)
SEQUENCE 5	1 CREDIT(S)
SEQUENCE 6	1 CREDIT(S)
SEQUENCE 7	1 CREDIT(S)
SEQUENCE 8	1 CREDIT(S)
-> EXIT	
[XXXXXXXXXXXXXXXXXXXXX]	
DESCRIPTION OF SEQUENCE	
1	CREDIT TO START
2	CREDIT TO CONTINUE
3	NO USE
4	NO USE
5	NO USE
6	NO USE
7	NO USE
8	NO USE
SELECT WITH SERVICE BUTTON	
AND	
PRESS TEST BUTTON	

1
4
4
4
2
4
4
4
3

This portion varies depending on specific games.

(EXAMPLE 1)

In cases of video games such as SPORTS JAM, ect. :
 SEQUENCE 1 : Number of credits required for game start (initial value=1)
 SEQUENCE 2 : Number of credits required for CONTINUE (initial value=1)
 SEQUENCE 3 ~ 8 : NOT USED.

(EXAMPLE 2)

In the case NAOMI is used as vending machiness:
 SEQUENCE 1 ~ 4 : Number of credits required for purchasing product 1 ~ 4 (Initial value=1)
 SEQUENCE 5 ~ 8 : Number of credits required for purchasing product 5 ~ 8 (Initial value=1)

5 - 7 BOOKKEEPING

- BOOKKEEPING 1/2

This allows such data as operating time/No. of coins inserted/ No. of credits to be checked.

BOOKKEEPING 1/2		
TOTAL TIME		
0D 00H 00M 00S		
CREDIT 1	0	(A)
CREDIT 2	0	
COIN 1	0	(B)
COIN 2	0	
TOTAL COIN	0	
COIN CREDIT	0	
SERVICE CREDIT	0	
TOTAL CREDIT	0	
PRESS TEST BUTTON TO CONTINUE		

(A) CREDIT 1,2 (,3,4)

(B) COIN 1,2 (,3,4)

Number of Display Items vary depending on the setting of CABINET TYPE in the SYSTEM ASSIGNMENTS.

Press the TEST button to proceed to BOOKKEEPING 2/2.

- BOOKKEEPING 2/2

Each sequence displays the frequency of functioning. The contents of each sequence vary depending on specific games. For the contents of each sequence, refer to the Instruction Manual of the game connected.

Display Items vary depending on the setting of CABINET TYPE in the SYSTEM ASSIGNMENTS.

BOOKKEEPING 2/2			
P1 SEQ 1	0	P2 SEQ 1	0
P1 SEQ 2	0	P2 SEQ 2	0
P1 SEQ 3	0	P2 SEQ 3	0
P1 SEQ 4	0	P2 SEQ 4	0
P1 SEQ 5	0	P2 SEQ 5	0
P1 SEQ 6	0	P2 SEQ 6	0
P1 SEQ 7	0	P2 SEQ 7	0
P1 SEQ 8	0	P2 SEQ 8	0
P3 SEQ 1	0	P4 SEQ 1	0
P3 SEQ 2	0	P4 SEQ 2	0
P3 SEQ 3	0	P4 SEQ 3	0
P3 SEQ 4	0	P4 SEQ 4	0
P3 SEQ 5	0	P4 SEQ 5	0
P3 SEQ 6	0	P4 SEQ 6	0
P3 SEQ 7	0	P4 SEQ 7	0
P3 SEQ 8	0	P4 SEQ 8	0
PRESS TEST BUTTON TO EXIT			

(EXAMPLE) In cases of video games such as SPORTS JAM, etc. :

P1(P2) SEQ 1 : Play frequency of Player 1 (Player 2)

P1(P2) SEQ 2 : Frequency of CONTINUE by Player (Player 2)

P1(P2) SEQ 3 ~ 8 : NOT USED.

5 - 8 BACKUP DATA CLEAR

Clears the contents of BOOKKEEPING.

BACKUP DATA CLEAR

YES(CLEAR)
-> NO(CANCEL)

SELECT WITH SERVICE BUTTON
AND
PRESS TEST BUTTON

When clearing, bring the arrow to YES by using the SERVICE button and press the TEST button. Bring the arrow to NO and press the TEST button to have the menu mode return without clearing the data. COMPLETED is displayed when clearing is completed. Press the TEST button to return to the menu mode.

5 - 9 CLOCK SETTING

Set YEAR, MONTH, DAY, HOUR, and MINUTE for NAOMI Main BD.

CLOCK SETTING

2000 11/15 05:10 32 WED

YEAR
MONTH
DAY
HOUR
MINUTE
-> EXIT

SELECT WITH SERVICE BUTTON
AND
PRESS TEST BUTTON

Select the desired item with the SERVICE button and press the TEST button to increase the value. Upon finishing the SETTING, bring the arrow to EXIT and press the TEST button to return to the menu mode.

5 - 10 DIMM BOARD TEST

This DIMM BOARD TEST screen appears only when a DIMM board is connected to the NAOMI. The ROM BOARD TEST screen appears instead when a ROM board is connected to the NAOMI.

This screen tests the DIMM memories and ICs on the DIMM board. When any problem is detected by the test, GOOD is displayed on the right of each testing item.

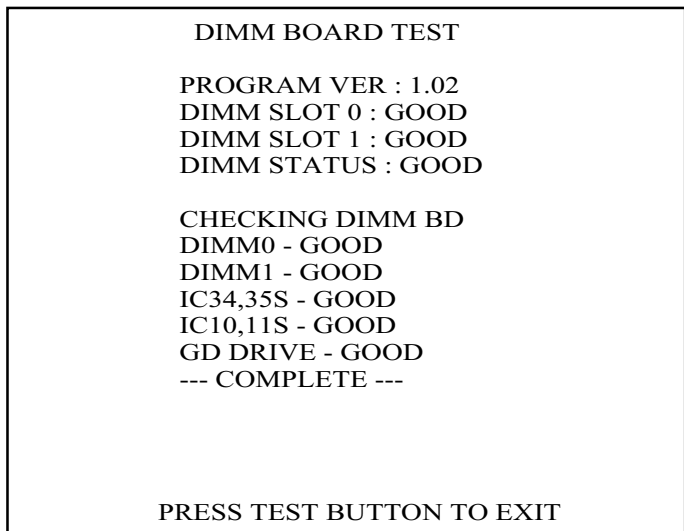

After finishing the test, press the TEST button to return to the Menu screen.

5 - 11 GAME TEST MODE

Enters the TEST mode of the game connected. The TEST mode includes INPUT test, GAME ASSIGNMENTS such as game difficulty and others, BOOKKEEPING, etc. Depending on specific games, necessary items are added and unnecessary items removed. As such, the contents thereof may be changed. For details, refer to the attached Instruction Manual.

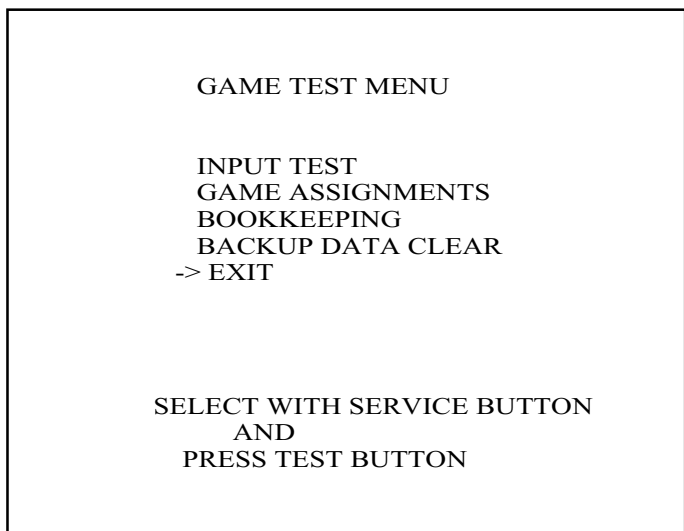

VISIT OUR WEBSITE!



SEGA ENTERPRISES, INC. (USA)

45133 Industrial Drive
Fremont, CA 94538
(415) 701-6580 phone
(415) 701-6594 fax